

## MF105-2Z

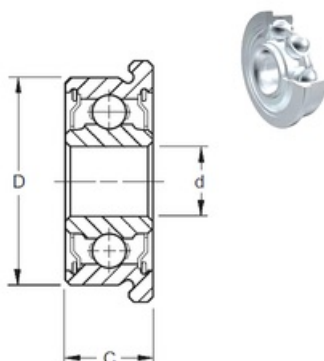

### Technical sheet of MF105-2Z

<b>Type :</b>	Flanged bearings	
<b>Model :</b>	<a href="#">MF105-2Z</a>	
<b>Main demensions :</b>	5 mm × 10 mm × 4 mm	Bore Dia × Outside Dia × Width Dia
<b>M kg:</b>	0.001	Mass
<b>HS Code :</b>	8482102000	Bearing customs code
<b>d mm:</b>	5	inner ring diameter
<b>D mm:</b>	10	Outer ring diameter
<b>B(T) mm:</b>	4	Overall Width
<b>Cr kN:</b>	0.431	Radial dynamic load rating
<b>CO<sub>r</sub> kN:</b>	0.169	Radial static load rating
<b>Grease r/min:</b>	50000	Reference speed

#### Detailed parameters and installation dimensions:

d: 5 mm  
 D: 10 mm  
 B: 4 mm  
 C: 4 mm  
 Cr: 0.431 kN  
 Cor: 0.169 kN  
 Grease rpm: 50000 r/min

Part Number: MF105-2Z

Technical description (2Z): 2Z=Shield Of Pressed Sheet Steel On Both Sides Of The Bearing.

Bearing Type: Deep Groove Ball Bearings, Single Row

Bearing Size (metric): Bore Dia. (d): 5 mm X Outer dia. (D): 10 mm X Width (B): 4 mm or Size: 5 mm \* 10 mm \* 4 mm

Original Equipment Manufacture(OEM NO.): MF105-2Z

Bore: C (Cylindrical Bore)

Seals Type: ZZ/2Z (Steel Material Seals on both sides)

Cage Design: S (Steel or Standard Cage)

External structure description: F - Flange

Radial internal clearance: Cn (Normal Internal clearance)

Precision Rating: Standard class precision

Type of lubrication: Standard class lubrication

Thermal Stability: No Thermal Stability - Temperatures up to 120°C

**NOTE:** All other trademarks are the property of their respective owners used for the purpose of compatibility description and product identification only. Tradebearings is not affiliated with, endorsed by, or sponsored by the holders of these trademarks.

**Tradebearing(TBS):** <https://en.tradebearings.com/>

Email: [admin@tradebearings.com](mailto:admin@tradebearings.com)

Whatsapp/Mob.: +86 15906428604