

81217

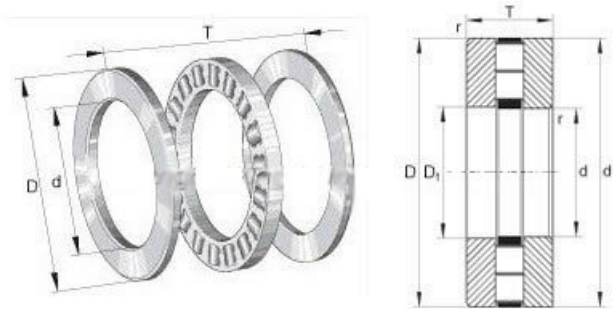

Technical sheet of 81217

Type :	Thrust Bearings	
Model :	81217	
Main demensions :	85 mm × 125 mm × 31 mm	Bore Dia × Outside Dia × Width Dia
M kg:	1.28	Mass
d mm:	85	inner ring diameter
D mm:	125	Outer ring diameter
B(T) mm:	31	Overall Width
Cr kN:	169000	Radial dynamic load rating
C0r kN:	550000	Radial static load rating
Grease r/min:	580	Reference speed
Oil r/min:	2300	Limiting speed

Tradebearing(TBS): <https://en.tradebearings.com/>

Email: admin@tradebearings.com
 Whatsapp/Mob.: +86 15906428604