

7009CE/DTVQ126

super-precision angular contact ball bearings

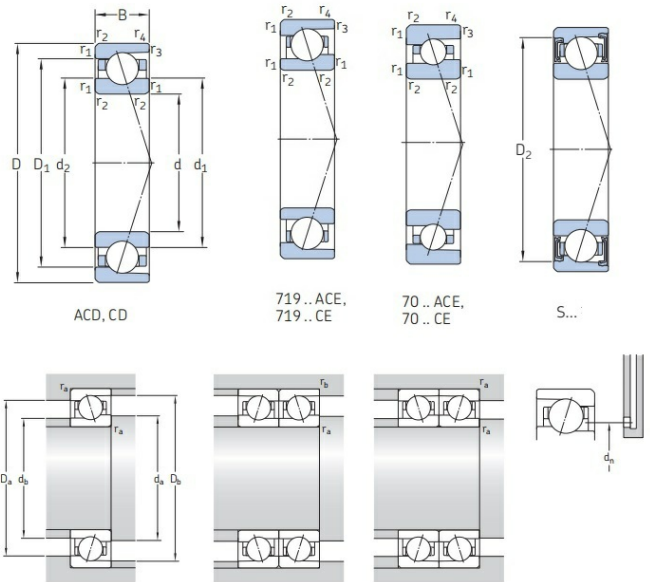

Technical sheet of 7009CE/DTVQ126

What are the Benefits of choosing 7009CE/DTVQ126 bearings?

- **High simultaneous load-bearing capacity:** Capable of simultaneously withstanding combined radial and axial loads and operating at high speeds.
- **High speed limit:** Optimized contact angle and cage design suitable for ultra-high-speed operation (e.g., machine tool spindles).
- **Rigidity and precision:** Provides extremely high rotational accuracy and system rigidity, ensuring precision in machining or operation.
- **Preload adjustment:** Precise preload adjustment is possible through paired installation (back-to-back/face-to-face), eliminating backlash and improving system stability.
- **Versatile design:** Offers different contact angles (e.g., 15°, 25°) to accommodate different speeds and load requirements.

Type :	High precision angular contact ball bearings	
Model :	7009CE/DTVQ126	
Main demensions :	45 mm × 75 mm × 32 mm	Bore Dia × Outside Dia × Width Dia
M kg:	0.48	Mass
HS Code :	8482103000	Bearing customs code
d mm:	45	inner ring diameter

D mm:	75	Outer ring diameter
B(T) mm:	32	Overall Width
Cr kN:	20.706	Radial dynamic load rating
C_{0r} kN:	16.905	Radial static load rating

Detailed parameters and installation dimensions:

Part Number	7009CE/DTVQ126
Internal design	CE = 15° contact angle, high-speed E design
Dimension series	ISO dimension series 10
Bearing Type	super-precision angular contact ball bearings
Series	70..-CE/DTVQ126
Rows NO.	2
Bearing Mass - m	0.48 kg 1.058 lb
Accuracy class	P4A
Cage	Cotton fabric reinforced phenolic resin or carbon fibre reinforced PEEK, outer ring centred
Seal	Open
Ball material	GCr15SiMn
Ring material	Carbon chromium steel
Bore Type	Z = Cylindrical Bore
Matched arrangement	Tandem <<
Arrangement and preload	DT = Set of two bearings arranged in tandem <<
Reference From	SKF 7009CE/DTVQ126
Dimension	
Bore - d ϕ	45 mm 1.772 inch
d tolerance	-0.004 mm to 0
Outside - D Φ	75 mm 2.953 inch
D tolerance	-0.004 mm to 0
Width - B	32 mm 1.260 inch
B tolerance	-0.2 mm to 0
Balls diameter	7.144 mm 0.281 inch
Balls qty	21
d ₁	55.7 mm
d ₂	53.6 mm
D ₁	64.25 mm
Chamfer - r ₁ ,r ₂ (min.)	1 mm
Chamfer - r ₃ ,r ₄ (min.)	0.6 mm
Fillet - r _a (max.)	1 mm
Fillet - r _b (max.)	0.6 mm
Load Capacity and speeds	
Dynamic Radial - C _r	20706 N 4654 lbf
Static Radial - C _{0r}	16905 N 3800 lbf

Fatigue Radial - P _u	685 N 153 lbf
Properties	
Axial clearance/preload	Not applicable
Lubrication	No
Contact angle - α	15 °
Universal matching	No
Temperature - T(min)	-30 °C
Temperature - T(max)	110 °C
Manufacturer Part Code	7009 CE/DTVQ126
Units	Metric
Load Direction	Angular Contact
Contact type	2-point contact
Ring type	inner rings(1 piece), outer rings(1 piece)
Coating	No
Reference grease quantity - G _{ref}	3.4 cm ³
Coefficient - f ₀	8.2
Abutment dimensions	
d _a (min.)	49.6 mm
d _b (min.)	49.6 mm
D _a (max.)	70.4 mm
D _b (max.)	70.8 mm
d _n	57.6 mm

What are the applications of the 7009CE/DTVQ126 bearing?

- **Machine tool manufacturing (spindles, grinding heads):** Achieve extremely high speeds and machining accuracy, improving surface quality and production efficiency.
- **Aerospace (accessory gearboxes, gyroscopes):** Maintain high reliability and long lifespan during high-speed operation, adapting to harsh environments.
- **Precision instruments (measuring equipment, optical instruments):** Provide extremely low vibration and smooth operation, ensuring measurement accuracy.
- **High-speed motors (electric spindles, permanent magnet motors):** Support ultra-high speed operation, reducing temperature rise and power consumption.
- **Semiconductor equipment (wafer dicing machines, lithography machines):** Ensure micron-level positioning accuracy and long-term stability, improving yield.
- **Medical devices (CT scanners, surgical robots):** Achieve quiet and smooth rotation, meeting medical safety standards.
- **Robotics (joint reducers):** Improve joint response speed and repeatability, enhancing dynamic performance.

How should choose the right model for a High precision angular contact ball bearings?

Step 1: Select Series by Size

Determine the ISO size series based on installation space and load requirements:

718 Series: Ultra-light, extremely low cross-section height, suitable for space-constrained applications.

719 Series: Extremely light, a general-purpose choice, balancing rigidity and speed.

70 Series: Light, the most commonly used series, with a wide range of applications.

72 Series: Robust, largest cross-section, suitable for heavy-duty, relatively low-speed applications.

Step 2: Select Internal Design by Working Condition (Crucial)

This is the core of SKF selection; different suffixes correspond to different performance orientations:

High Load Capacity D Design: Suffix CD (15° contact angle) or ACD (25° contact angle). Utilizes a large ball design, offering the highest rigidity and load-bearing capacity, suitable for general-purpose machine tool spindles such as machining centers and lathes.

High Speed E Design: Suffix CE (15°), FE (18°), or ACE (25°). Featuring a small, multi-ball design, this bearing boasts higher speed capabilities than the D design, suitable for ultra-high-speed applications such as electric spindles and PCB drilling.

High-Speed B Design: Suffixes CB (15°), FB (18°), or ACB (25°). Smaller and lighter balls, suitable for extremely high speeds and light loads.

UltraFast A Design: Suffix AB (20° contact angle). Available only with hybrid ceramic balls, designed specifically for electric spindles demanding extreme speeds.

Sealed W Design: Suffix FW (18° contact angle). Available only with hybrid ceramic balls, featuring double-sided sealing and lifetime lubrication, suitable for medium-to-high-speed, maintenance-free equipment such as woodworking machinery.

Step 3: Identifying the Seal and Suffix

Seal Identification (Prefix): Models starting with S indicate double-sided sealing (e.g., S7010), pre-filled with grease at the factory, requiring no maintenance for life. Those without S are open bearings.

Material: HC indicates hybrid ceramic balls (ceramic balls + steel rings), enabling higher speeds, electrical insulation, and longer lifespan.

Preload (universal pairing): GA (ultra-light preload), GB (light preload), GC (medium preload). This is a suffix for a single bearing, indicating that the bearing can be arbitrarily paired and combined to achieve a specified preload.

Precision: P4 (ISO Class 4, standard ultra-precision), P4A (operating precision higher than P4), P2 (highest grade).

Arrangement (pair/group suffix): DB (back-to-back), DF (face-to-face), DT (tandem), QBC (quadruple, tandem back-to-back configuration), etc.

Typical Model Explanation

Taking S7010 ACD/HCP4A QBC C as an example:

S: Double-sided seal (lifetime lubrication)

7010: 70 series, 50mm inner diameter

ACD: 25° contact angle, D design (high load capacity)

HC: Hybrid ceramic balls

P4A: Precision grade (super P4)

QBC: Quadruple bearing assembly, tandem back-to-back configuration

C: Medium preload (for heavy preload)

Taking 71922 CDGB TNHA/PA9A L as an example:

71922: 719 series, 110mm inner diameter

CD: 15° contact angle, D design (high load capacity)
GB: Light preload (universal matching)
TNHA: Glass fiber reinforced PEEK cage, outer ring centering
PA9A: Precision grade (ISO) Level 2)
L: Light preload (for triple/quadruple units only)

Selection Key Points Summary

First determine the series: 718/719/70/72

Then determine the design: CD/ACD (high load capacity) or CE/ACE (high speed) or FW (sealing) or AB (UltraFast)

Confirm the seal: Select the S prefix for lifetime lubrication

Optional suffixes: Material HC, Preload GA/GB/GC, Accuracy P4/P4A, Arrangement DB/DF/DT/QBC

What is the mounting procedure for 7009CE/DTVQ126 bearings?

Cleaning and Inspection: Clean the bearing in a dust-free environment. After a rough wash to remove contaminants, perform a fine wash until the bearing feels smooth and responsive to the touch. Simultaneously check the accuracy of the mating surfaces of the shaft and bearing housing.

Measurement and Fitting: Precisely measure the bearing's inner and outer diameters. Mark the corresponding positions on the shaft and housing bores for alignment during assembly to compensate for any deviations.

Installation and Positioning: Apply pressure evenly using a specialized tool, focusing only on the interference fit rings. If heat fitting is used, tighten the inner ring during cooling to prevent clearance from affecting the preload.

Preload Adjustment: When installing in pairs, ensure the parallelism of the inner and outer spacers is $\leq 1\mu\text{m}$. Adjust the preload force to the specified value by grinding the spacers.

Lubrication Inspection: Add the specified amount of grease or oil mist lubricant. After installation, manually rotate the bearing to check its flexibility and operating noise.

Special Note for mounting 7009CE/DTVQ126 bearings?

Clean Environment: Operation must be performed in a dust-free cleanroom with humidity $\leq 65\%$ to prevent dust and impurities from affecting accuracy.

No Striking: Direct striking of the bearings is strictly prohibited. Special tools must be used, and force must be applied evenly.

Matching Marks: Bearings used in pairs are not interchangeable. Installation must strictly follow the factory matching marks.

Rust-Proof Storage: Long-term storage requires regular rust-proofing treatment. Maintain ventilation and avoid corrosive gases.

Tradebearing(TBS): <https://en.tradebearings.com/>

Email: admin@tradebearings.com

