

## 7001CD/DTVQ253

Super-precision angular contact ball bearings, single row

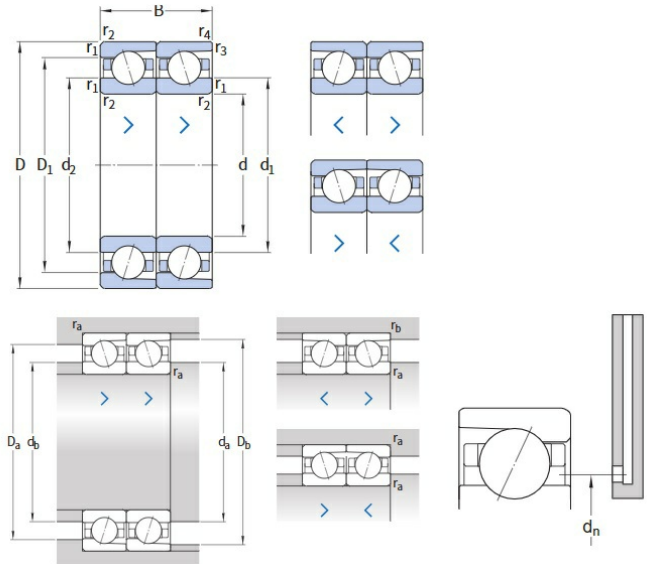

### Technical sheet of 7001CD/DTVQ253

#### What are the Benefits of choosing 7001CD/DTVQ253 bearings?

- **High simultaneous load-bearing capacity:** Capable of simultaneously withstanding combined radial and axial loads and operating at high speeds.
- **High speed limit:** Optimized contact angle and cage design suitable for ultra-high-speed operation (e.g., machine tool spindles).
- **Rigidity and precision:** Provides extremely high rotational accuracy and system rigidity, ensuring precision in machining or operation.
- **Preload adjustment:** Precise preload adjustment is possible through paired installation (back-to-back/face-to-face), eliminating backlash and improving system stability.
- **Versatile design:** Offers different contact angles (e.g., 15°, 25°) to accommodate different speeds and load requirements.

Type :	Angular contact ball bearings, super-precision	
Model :	<a href="#">7001CD/DTVQ253</a>	
Main demensions :	12 mm × 28 mm × 16 mm	Bore Dia × Outside Dia × Width Dia
M kg:	0.0415	Mass
HS Code :	8482103000	Bearing customs code
d mm:	12	inner ring diameter
D mm:	28	Outer ring diameter

**Detailed parameters and installation dimensions:**

<b>Key Characteristics:</b>	
Part Number	7001CD/DTVQ253
Bearing Type	Super-precision angular contact ball bearings, single row
Design	CD = contact angle 15°, high-capacity D design
Cage	Cotton fabric reinforced phenolic resin or carbon fibre reinforced PEEK, outer ring centred
Series	7000 series (70..CD/DTVQ253)
Dimension series	70 = (ISO dimension series 10)
Contact angle - $\alpha$	CD = 15 °
Seal	Open
Contact type	Normal contact (2-point contact)
Interchangeable	SKF 7001CD/DTVQ253
Arrangement	DT = two bearings arranged in tandem <<
Universal matching	Single standalone bearing
Number of bearings (Arrangement)	2
Load	radial and axial
Bore Type	Cylindrical
Coating	No
Lubricant	No
Temperature - T(min)	-30 °C
Temperature - T(max)	110 °C
Units	Metric
Ring type	(1) inner, (1) outer rings
Inner/Outer Ring Material	Carbon chromium steel
Rolling Element Material	Carbon chromium steel
Number of rows (per) - i	One
Manufacturer Part Code	7001 CD/DTVQ253
Bearing Mass - m	0.0415 kg   0.091 lb
<b>Dimensions:</b>	
Dimension Inside - d $\phi$	12 mm   0.472 inch
Dimension Outside - D $\Phi$	28 mm   1.102 inch
Dimension Width - B	16 mm   0.630 inch

**What are the applications of the 7001CD/DTVQ253 bearing?**

- **Machine tool manufacturing (spindles, grinding heads):** Achieve extremely high speeds and machining accuracy, improving surface quality and production efficiency.
- **Aerospace (accessory gearboxes, gyroscopes):** Maintain high reliability and long lifespan during high-speed operation, adapting to harsh environments.
- **Precision instruments (measuring equipment, optical instruments):** Provide extremely low vibration and smooth operation, ensuring measurement accuracy.
- **High-speed motors (electric spindles, permanent magnet motors):** Support ultra-high speed

operation, reducing temperature rise and power consumption.

- **Semiconductor equipment (wafer dicing machines, lithography machines):** Ensure micron-level positioning accuracy and long-term stability, improving yield.
- **Medical devices (CT scanners, surgical robots):** Achieve quiet and smooth rotation, meeting medical safety standards.
- **Robotics (joint reducers):** Improve joint response speed and repeatability, enhancing dynamic performance.

## How should choose the right model for a Angular contact ball bearings, super-precision?

### Step 1: Select Series by Size

Determine the ISO size series based on installation space and load requirements:

718 Series: Ultra-light, extremely low cross-section height, suitable for space-constrained applications.

719 Series: Extremely light, a general-purpose choice, balancing rigidity and speed.

70 Series: Light, the most commonly used series, with a wide range of applications.

72 Series: Robust, largest cross-section, suitable for heavy-duty, relatively low-speed applications.

### Step 2: Select Internal Design by Working Condition (Crucial)

This is the core of SKF selection; different suffixes correspond to different performance orientations:

High Load Capacity D Design: Suffix CD (15° contact angle) or ACD (25° contact angle). Utilizes a large ball design, offering the highest rigidity and load-bearing capacity, suitable for general-purpose machine tool spindles such as machining centers and lathes.

High Speed E Design: Suffix CE (15°), FE (18°), or ACE (25°). Featuring a small, multi-ball design, this bearing boasts higher speed capabilities than the D design, suitable for ultra-high-speed applications such as electric spindles and PCB drilling.

High-Speed B Design: Suffixes CB (15°), FB (18°), or ACB (25°). Smaller and lighter balls, suitable for extremely high speeds and light loads.

UltraFast A Design: Suffix AB (20° contact angle). Available only with hybrid ceramic balls, designed specifically for electric spindles demanding extreme speeds.

Sealed W Design: Suffix FW (18° contact angle). Available only with hybrid ceramic balls, featuring double-sided sealing and lifetime lubrication, suitable for medium-to-high-speed, maintenance-free equipment such as woodworking machinery.

### Step 3: Identifying the Seal and Suffix

Seal Identification (Prefix): Models starting with S indicate double-sided sealing (e.g., S7010), pre-filled with grease at the factory, requiring no maintenance for life. Those without S are open bearings.

Material: HC indicates hybrid ceramic balls (ceramic balls + steel rings), enabling higher speeds, electrical insulation, and longer lifespan.

Preload (universal pairing): GA (ultra-light preload), GB (light preload), GC (medium preload). This is a suffix for a single bearing, indicating that the bearing can be arbitrarily paired and combined to achieve a specified preload.

Precision: P4 (ISO Class 4, standard ultra-precision), P4A (operating precision higher than P4), P2 (highest grade).

Arrangement (pair/group suffix): DB (back-to-back), DF (face-to-face), DT (tandem), QBC (quadruple, tandem back-to-back configuration), etc.

### Typical Model Explanation

Taking S7010 ACD/HCP4A QBC C as an example:

S: Double-sided seal (lifetime lubrication)  
7010: 70 series, 50mm inner diameter  
ACD: 25° contact angle, D design (high load capacity)  
HC: Hybrid ceramic balls  
P4A: Precision grade (super P4)  
QBC: Quadruple bearing assembly, tandem back-to-back configuration  
C: Medium preload (for heavy preload)

Taking 71922 CDGB TNHA/PA9A L as an example:

71922: 719 series, 110mm inner diameter  
CD: 15° contact angle, D design (high load capacity)  
GB: Light preload (universal matching)  
TNHA: Glass fiber reinforced PEEK cage, outer ring centering  
PA9A: Precision grade (ISO) Level 2)  
L: Light preload (for triple/quadruple units only)

### Selection Key Points Summary

First determine the series: 718/719/70/72  
Then determine the design: CD/ACD (high load capacity) or CE/ACE (high speed) or FW (sealing) or AB (UltraFast)  
Confirm the seal: Select the S prefix for lifetime lubrication  
Optional suffixes: Material HC, Preload GA/GB/GC, Accuracy P4/P4A, Arrangement DB/DF/DT/QBC

## What is the mounting procedure for 7001CD/DTVQ253 bearings?

**Cleaning and Inspection:** Clean the bearing in a dust-free environment. After a rough wash to remove contaminants, perform a fine wash until the bearing feels smooth and responsive to the touch. Simultaneously check the accuracy of the mating surfaces of the shaft and bearing housing.

**Measurement and Fitting:** Precisely measure the bearing's inner and outer diameters. Mark the corresponding positions on the shaft and housing bores for alignment during assembly to compensate for any deviations.

**Installation and Positioning:** Apply pressure evenly using a specialized tool, focusing only on the interference fit rings. If heat fitting is used, tighten the inner ring during cooling to prevent clearance from affecting the preload.

**Preload Adjustment:** When installing in pairs, ensure the parallelism of the inner and outer spacers is  $\leq 1\mu\text{m}$ . Adjust the preload force to the specified value by grinding the spacers.

**Lubrication Inspection:** Add the specified amount of grease or oil mist lubricant. After installation, manually rotate the bearing to check its flexibility and operating noise.

## Special Note for mounting 7001CD/DTVQ253 bearings?

**Clean Environment:** Operation must be performed in a dust-free cleanroom with humidity  $\leq 65\%$  to prevent dust and impurities from affecting accuracy.

**No Striking:** Direct striking of the bearings is strictly prohibited. Special tools must be used, and force must be applied evenly.

**Matching Marks:** Bearings used in pairs are not interchangeable. Installation must strictly follow the factory matching marks.

**Rust-Proof Storage:** Long-term storage requires regular rust-proofing treatment. Maintain ventilation and avoid corrosive gases.

**Tradebearing(TBS):** <https://en.tradebearings.com/>

Email: [admin@tradebearings.com](mailto:admin@tradebearings.com)

Whatsapp/Mob.: +86 15906428604