

7008CEGB/P4A

super-precision angular contact ball bearings

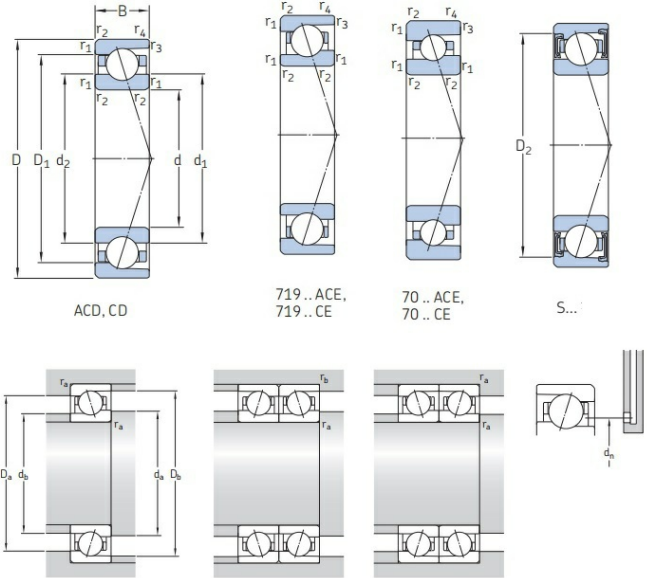

Technical sheet of 7008CEGB/P4A

What are the Benefits of choosing 7008CEGB/P4A bearings?

- **High simultaneous load-bearing capacity:** Capable of simultaneously withstanding combined radial and axial loads and operating at high speeds.
- **High speed limit:** Optimized contact angle and cage design suitable for ultra-high-speed operation (e.g., machine tool spindles).
- **Rigidity and precision:** Provides extremely high rotational accuracy and system rigidity, ensuring precision in machining or operation.
- **Preload adjustment:** Precise preload adjustment is possible through paired installation (back-to-back/face-to-face), eliminating backlash and improving system stability.
- **Versatile design:** Offers different contact angles (e.g., 15°, 25°) to accommodate different speeds and load requirements.

Type :	Angular Contact Ball Bearings	
Model :	7008CEGB/P4A	
Main demensions :	40 mm × 68 mm × 15 mm	Bore Dia × Outside Dia × Width Dia
M kg:	0.19	Mass
HS Code :	8482103000	Bearing customs code
d mm:	40	inner ring diameter

D mm:	68	Outer ring diameter
B(T) mm:	15	Overall Width
Cr kN:	12.302	Radial dynamic load rating
C0r kN:	7.512	Radial static load rating
Grease r/min:	29957	Reference speed
Oil r/min:	44888	Limiting speed

Detailed parameters and installation dimensions:

Part Number	7008CEGB/P4A
Bearing Type	super-precision angular contact ball bearings
Internal design	CE = 15° contact angle, high-speed E design
Series	70..-CEGB/P4A
Accuracy class	P4A
Rows NO.	1
Cage	Cotton fabric reinforced phenolic resin or carbon fibre reinforced PEEK, outer ring centred
Dimension series	ISO dimension series 10
Ball material	GCr15SiMn
Contact angle - α	15 °
Manufacturer Part Code	7008 CEGB/P4A
Dimension	
Inside - d ϕ	40 mm 1.575 inch
Outside - D Φ	68 mm 2.677 inch
Width - B	15 mm 0.591 inch
Chamfer - r_1, r_2 (min.)	1 mm 0.039 inch
Chamfer - r_3, r_4 (min.)	0.6 mm 0.024 inch
Fillet - r_a (max.)	1 mm 0.039 inch
Fillet - r_b (max.)	0.6 mm 0.024 inch
d_1	49.7 mm 1.957 inch
d_2	47.6 mm 1.874 inch
D_1	60.9 mm 2.398 inch
D_2	60.9 mm 2.398 inch
Balls diameter	7.144 mm 0.281 inch
Properties	
Bore Type	Z = Cylindrical Bore
Ring material	Carbon chromium steel
Balls qty [single]	19
Temperature - T(min)	-30 °C
Temperature - T(max)	+110 °C
Bearing Mass - m	0.19 kg 0.419 lb
Units	Metric
Contact type	2-point contact

Single bearing - execution and preload	GB = Single, universally matchable, moderate preload
Ring type	inner rings(1 piece), outer rings(1 piece)
Load Direction	Angular Contact
Seal	open
Grease quantity - G_{ref}	2.8 cm ³
Calculation coefficient - f_0	8.1
Performance (Load Capacity and speeds)	
Dynamic Radial - C_r	12302 N 2765 lbf
Static Radial - C_{0r}	7512 N 1688 lbf
Fatigue Radial - P_u	305 N 68 lbf
Attainable speeds (Grease)	29957 r/min
Attainable speeds (Oil-air)	44888 r/min
Abutment dimensions	
d_a (min.)	44.6 mm 1.756 inch
d_b (min.)	44.6 mm 1.756 inch
D_a (max.)	63.4 mm 2.496 inch
D_b (max.)	63.8 mm 2.512 inch
d_n	51.6 mm 2.031 inch

What are the applications of the 7008CEGB/P4A bearing?

- **Machine tool manufacturing (spindles, grinding heads):** Achieve extremely high speeds and machining accuracy, improving surface quality and production efficiency.
- **Aerospace (accessory gearboxes, gyroscopes):** Maintain high reliability and long lifespan during high-speed operation, adapting to harsh environments.
- **Precision instruments (measuring equipment, optical instruments):** Provide extremely low vibration and smooth operation, ensuring measurement accuracy.
- **High-speed motors (electric spindles, permanent magnet motors):** Support ultra-high speed operation, reducing temperature rise and power consumption.
- **Semiconductor equipment (wafer dicing machines, lithography machines):** Ensure micron-level positioning accuracy and long-term stability, improving yield.
- **Medical devices (CT scanners, surgical robots):** Achieve quiet and smooth rotation, meeting medical safety standards.
- **Robotics (joint reducers):** Improve joint response speed and repeatability, enhancing dynamic performance.

How should choose the right model for a Angular Contact Ball Bearings?

Step 1: Select Series by Size

Determine the ISO size series based on installation space and load requirements:

718 Series: Ultra-light, extremely low cross-section height, suitable for space-constrained applications.

719 Series: Extremely light, a general-purpose choice, balancing rigidity and speed.

70 Series: Light, the most commonly used series, with a wide range of applications.

72 Series: Robust, largest cross-section, suitable for heavy-duty, relatively low-speed applications.

Step 2: Select Internal Design by Working Condition (Crucial)

This is the core of SKF selection; different suffixes correspond to different performance orientations:

High Load Capacity D Design: Suffix CD (15° contact angle) or ACD (25° contact angle). Utilizes a large ball design, offering the highest rigidity and load-bearing capacity, suitable for general-purpose machine tool spindles such as machining centers and lathes.

High Speed E Design: Suffix CE (15°), FE (18°), or ACE (25°). Featuring a small, multi-ball design, this bearing boasts higher speed capabilities than the D design, suitable for ultra-high-speed applications such as electric spindles and PCB drilling.

High-Speed B Design: Suffixes CB (15°), FB (18°), or ACB (25°). Smaller and lighter balls, suitable for extremely high speeds and light loads.

UltraFast A Design: Suffix AB (20° contact angle). Available only with hybrid ceramic balls, designed specifically for electric spindles demanding extreme speeds.

Sealed W Design: Suffix FW (18° contact angle). Available only with hybrid ceramic balls, featuring double-sided sealing and lifetime lubrication, suitable for medium-to-high-speed, maintenance-free equipment such as woodworking machinery.

Step 3: Identifying the Seal and Suffix

Seal Identification (Prefix): Models starting with S indicate double-sided sealing (e.g., S7010), pre-filled with grease at the factory, requiring no maintenance for life. Those without S are open bearings.

Material: HC indicates hybrid ceramic balls (ceramic balls + steel rings), enabling higher speeds, electrical insulation, and longer lifespan.

Preload (universal pairing): GA (ultra-light preload), GB (light preload), GC (medium preload). This is a suffix for a single bearing, indicating that the bearing can be arbitrarily paired and combined to achieve a specified preload.

Precision: P4 (ISO Class 4, standard ultra-precision), P4A (operating precision higher than P4), P2 (highest grade).

Arrangement (pair/group suffix): DB (back-to-back), DF (face-to-face), DT (tandem), QBC (quadruple, tandem back-to-back configuration), etc.

Typical Model Explanation

Taking S7010 ACD/HCP4A QBC C as an example:

S: Double-sided seal (lifetime lubrication)

7010: 70 series, 50mm inner diameter

ACD: 25° contact angle, D design (high load capacity)

HC: Hybrid ceramic balls

P4A: Precision grade (super P4)

QBC: Quadruple bearing assembly, tandem back-to-back configuration

C: Medium preload (for heavy preload)

Taking 71922 CDGB TNHA/PA9A L as an example:

71922: 719 series, 110mm inner diameter

CD: 15° contact angle, D design (high load capacity)

GB: Light preload (universal matching)

TNHA: Glass fiber reinforced PEEK cage, outer ring centering

PA9A: Precision grade (ISO) Level 2)

L: Light preload (for triple/quadruple units only)

Selection Key Points Summary

First determine the series: 718/719/70/72

Then determine the design: CD/ACD (high load capacity) or CE/ACE (high speed) or FW (sealing) or AB (UltraFast)

Confirm the seal: Select the S prefix for lifetime lubrication

Optional suffixes: Material HC, Preload GA/GB/GC, Accuracy P4/P4A, Arrangement DB/DF/DT/QBC

What is the mounting procedure for 7008CEGB/P4A bearings?

Cleaning and Inspection: Clean the bearing in a dust-free environment. After a rough wash to remove contaminants, perform a fine wash until the bearing feels smooth and responsive to the touch. Simultaneously check the accuracy of the mating surfaces of the shaft and bearing housing.

Measurement and Fitting: Precisely measure the bearing's inner and outer diameters. Mark the corresponding positions on the shaft and housing bores for alignment during assembly to compensate for any deviations.

Installation and Positioning: Apply pressure evenly using a specialized tool, focusing only on the interference fit rings. If heat fitting is used, tighten the inner ring during cooling to prevent clearance from affecting the preload.

Preload Adjustment: When installing in pairs, ensure the parallelism of the inner and outer spacers is $\leq 1\mu\text{m}$. Adjust the preload force to the specified value by grinding the spacers.

Lubrication Inspection: Add the specified amount of grease or oil mist lubricant. After installation, manually rotate the bearing to check its flexibility and operating noise.

Special Note for mounting 7008CEGB/P4A bearings?

Clean Environment: Operation must be performed in a dust-free cleanroom with humidity $\leq 65\%$ to prevent dust and impurities from affecting accuracy.

No Striking: Direct striking of the bearings is strictly prohibited. Special tools must be used, and force must be applied evenly.

Matching Marks: Bearings used in pairs are not interchangeable. Installation must strictly follow the factory matching marks.

Rust-Proof Storage: Long-term storage requires regular rust-proofing treatment. Maintain ventilation and avoid corrosive gases.

Tradebearing(TBS): <https://en.tradebearings.com/>

Email: admin@tradebearings.com

Whatsapp/Mob.: +86 15906428604