

HCB7002-C-2RSD-T-P4S-K5-QBCL

Super Precision Hybrid Angular Contact Ball Bearing

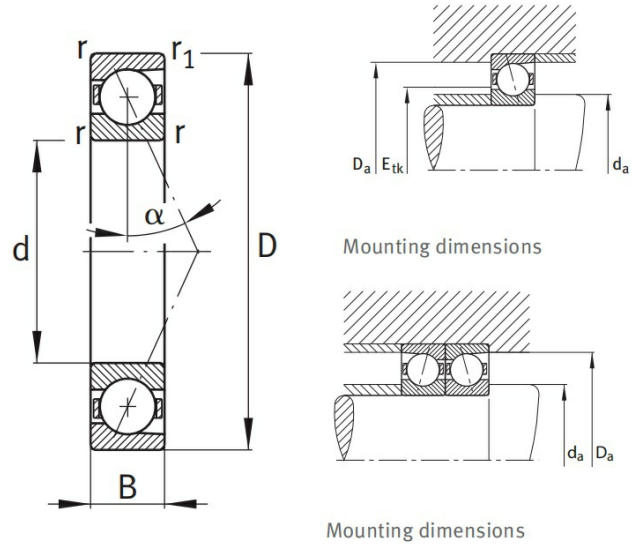

Technical sheet of HCB7002-C-2RSD-T-P4S-K5-QBCL

Type :	Precision spindle bearings	
Model :	HCB7002-C-2RSD-T-P4S-K5-QBCL	
Old Code :	HCB7002C2RSDTP4SK5QBCL	
Main demensions :	15 mm × 32 mm × 9 mm	Bore Dia × Outside Dia × Width Dia
M kg:	0.027	Mass
d mm:	15	inner ring diameter
D mm:	32	Outer ring diameter
B(T) mm:	9	Overall Width
Cr kN:	6.07	Radial dynamic load rating
C0r kN:	2.275	Radial static load rating
Grease r/min:	69966	Reference speed
Oil r/min:	109807	Limiting speed

Detailed parameters and installation dimensions:

Part Number	HCB7002-C-2RSD-T-P4S-K5-QBCL
Design Type	HCB = Hybrid Standard bearing, Lager balls, Ceramic balls
Series	HCB70..-C-2RSD-T-P4S-K5-QBCL

Contact angle - α	(C) 15 °
Dimension series	70 (Medium series)
Reference From	FAG HCB7002-C-2RSD-T-P4S-K5-QBCL
Dimension Inside - $d \phi$ (mm)	15
Dimension Outside - $D \Phi$ (mm)	32
Dimension Width - B (mm)	9
Bearing set	QBCL
Accuracy class	P4S-K5
Dimension - r(min.)	0.3 mm 0.012 inch
Dimension - r_1 (min.)	0.3 mm 0.012 inch
Seal	2RSD = Sealed on both sides
Reference speed (grease) - n_B	69966 min ⁻¹
Limiting speed (oil) - n_G	109807 min ⁻¹
Arrangement	QBC = Set of 4 bearings Tandem - O - arrangement
Preload	L = Preload Light
Mounting dimensions - d_a (h12)	19 mm 0.748 inch
Mounting dimensions - D_a (H12)	29 mm 1.142 inch
Bearing Type	Super Precision Hybrid Angular Contact Ball Bearing
Row No.	Four
Bore Type	Z = Cylindrical bore
Mounting dimensions - E_{tk} (nom.)	22.3 mm 0.878 inch
Dimension Inside - $d \phi$ (inch)	0.591
Dimension Outside - $D \Phi$ (inch)	1.260
Dimension Width - B (inch)	0.354
Manufacturer Part Code	HCB7002C2RSDTP4SK5QBCL , HCB7002C-2RSD-T-P4S-K5-QBCL
Temperature - T(min)	-30°C
Temperature - T(max)	+100°C
Units	Metric
Radial Dynamic Capacity - C_r	6070 N 1364 lbf
Bearing Mass - m	0.027 kg 0.060 lb
Cage	T = Laminated fabric, guidance on outer ring
Radial static Capacity - C_{0r}	2275 N 511 lbf
Preload force - F_v L	12 N 2 lbf
Preload force - F_v M	52 N 11 lbf
Preload force - F_v H	112 N 25 lbf
Ball Material	Ceramic
Axial rigidity - c_a L	13.4 N/ μ m
Axial rigidity - c_a M	24.3 N/ μ m
Axial rigidity - c_a H	35.1 N/ μ m
Ring Material	GCr15SiMn
Lift-off force - K_{aE} L	31 N 6 lbf
Lift-off force - K_{aE} M	162 N 36 lbf
Lift-off force - K_{aE} H	421 N 94 lbf

NOTE: All other trademarks are the property of their respective owners, used for the purpose of compatibility description and product identification only. Tradebearings is not affiliated with, endorsed by, or sponsored by the holders of these trademarks.

HCB7002-C-2RSD-T-P4S-K5-QBCL features:

1. Fundamental advantages of ceramic balls materials:

Extremely low density: Weighs only 40% of steel balls. Reduces friction, heat generation, and wear.

Low coefficient of thermal expansion: Only 25%-30% of steel. Excellent thermal stability and good spindle accuracy retention.

High hardness and wear resistance: Hardness exceeds that of bearing steel, improving fatigue life.

Excellent chemical inertness: Corrosion resistant, can operate in certain special media.

Non-magnetic and insulating: Does not generate magnetic interference and is unaffected by electromagnetic fields.

2. Design advantages of ultra-precision angular contact structures:

High stiffness: Backlash can be eliminated through preload, providing extremely high axial and radial stiffness.

High precision: "Ultra-precision" manufacturing (P4, P2, or higher, or ABEC 7, 9 standards) ensures minimal trajectory error.

High load-bearing capacity: Specific contact angle design can simultaneously withstand combined radial and axial loads.

3. Comprehensive Superior Performance:

Balance between Speed and Temperature Rise: Operates more calmly at higher speeds, avoiding the "thermal failure" bottleneck of steel bearings.

Extra-Long Service Life: Under the same operating conditions, its service life is typically 3-5 times longer than that of high-grade steel bearings.

High Performance Consistency: Under varying operating conditions and wide temperature ranges, performance fluctuations are far less than those of steel bearings.

HCB7002-C-2RSD-T-P4S-K5-QBCL application:

1. Ultra-precision CNC machine tools and machining centers: High-speed electric spindles (high-speed milling and precision engraving of molds and aerospace parts (aluminum alloys/composite materials); precision grinding spindles (for high-precision grinding of bearings, gears, and tool edges).

2. Semiconductor manufacturing equipment: Lithography machines (wafer platforms, objective systems, and other ultra-precision motion platforms); packaging and testing equipment (high-precision placement heads, probe station spindles).

3. High-end robot reducers: Key bearings in RV reducers and harmonic reducers.

4. Aerospace and special fields: Aero-engine accessory systems, UAV electric drive systems, missile guidance gyroscopes; vacuum turbomolecular pump spindles.

5. Other high-tech instruments: High-speed centrifuges (medical blood separators, laboratory centrifuges); precision measuring instruments (roundness testers, high-precision rotary tables).

Tradebearing(TBS): <https://en.tradebearings.com/>

Email: admin@tradebearings.com

Whatsapp/Mob.: +86 15906428604