

B7208-E-T-P4S-UL

Super Precision Angular Contact Ball Bearing

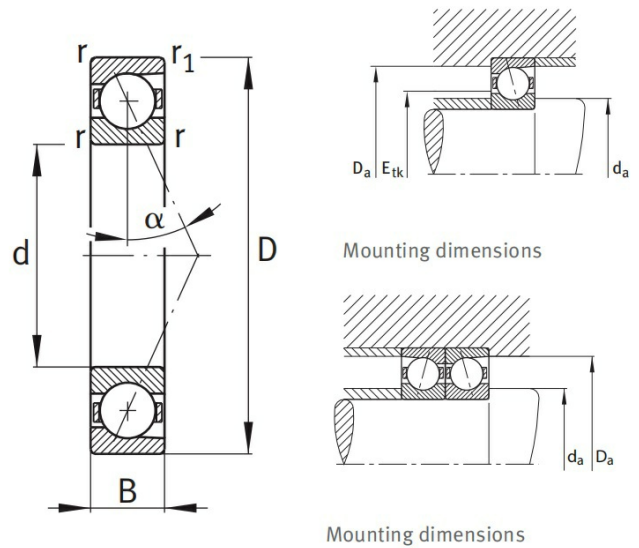

Technical sheet of B7208-E-T-P4S-UL

What are the Benefits of choosing B7208-E-T-P4S-UL bearings?

- **High simultaneous load-bearing capacity:** Capable of simultaneously withstanding combined radial and axial loads and operating at high speeds.
- **High speed limit:** Optimized contact angle and cage design suitable for ultra-high-speed operation (e.g., machine tool spindles).
- **Rigidity and precision:** Provides extremely high rotational accuracy and system rigidity, ensuring precision in machining or operation.
- **Preload adjustment:** Precise preload adjustment is possible through paired installation (back-to-back/face-to-face), eliminating backlash and improving system stability.
- **Versatile design:** Offers different contact angles (e.g., 15°, 25°) to accommodate different speeds and load requirements.

Type :	High precision angular contact ball bearings	
Model :	B7208-E-T-P4S-UL	
Old Code :	B7208ETP4SUL	
Main demensions :	40 mm × 80 mm × 18 mm	Bore Dia × Outside Dia × Width Dia
M kg:	0.371	Mass
HS Code :	8482103000	Bearing customs code

d mm:	40	inner ring diameter
D mm:	80	Outer ring diameter
B(T) mm:	18	Overall Width
Cr kN:	30.875	Radial dynamic load rating
C_{0r} kN:	15.248	Radial static load rating
Grease r/min:	16861	Reference speed
Oil r/min:	27956	Limiting speed

Detailed parameters and installation dimensions:

Part Number	B7208-E-T-P4S-UL
Design Type	B = Standard bearing, Lager balls, Steel balls
Series	B72..-E-T-P4S-UL
Bearing Type	Super Precision Angular Contact Ball Bearing
Contact angle - α	(E) 25 °
Dimension series	72 (Heavy series)
Bearing set	UL
Accuracy class	P4S
Seal	Open
Arrangement	U = Single bearing arrangeable as desired
Preload	L = Preload Light
Row No.	One
Bore Type	Z = Cylindrical bore
Units	Metric
Bearing Mass - m	0.371 kg 0.818 lb
Cage	T = Laminated fabric, guidance on outer ring
Ball Material	GCr15SiMn
Ring Material	GCr15SiMn
Manufacturer Part Code	B7208ETP4SUL , B7208E-T-P4S-UL
Reference From	FAG B7208-E-T-P4S-UL
Dimension Inside - d ϕ (mm)	40
Dimension Outside - D Φ (mm)	80
Dimension Width - B (mm)	18
Dimension - r(min.)	1.1 mm 0.043 inch
Dimension - r ₁ (min.)	1.1 mm 0.043 inch
Temperature - T(min)	-30°C
Temperature - T(max)	+100°C
Radial Dynamic Capacity - C _r	30875 N 6940 lbf
Radial static Capacity - C _{0r}	15248 N 3427 lbf
Reference speed (grease) - n _B	16861 min ⁻¹
Limiting speed (oil) - n _G	27956 min ⁻¹
Mounting dimensions - d _a (h12)	48 mm 1.890 inch
Mounting dimensions - D _a (H12)	72 mm 2.835 inch

Mounting dimensions - E_{tk} (nom.)	57.2 mm 2.252 inch
Preload force - $F_V L$	272 N 61 lbf
Preload force - $F_V M$	918 N 206 lbf
Preload force - $F_V H$	1928 N 433 lbf
Axial rigidity - $c_a L$	110 N/ μ m
Axial rigidity - $c_a M$	181 N/ μ m
Axial rigidity - $c_a H$	250 N/ μ m
Lift-off force - $K_{aE} L$	758 N 170 lbf
Lift-off force - $K_{aE} M$	2755 N 619 lbf
Lift-off force - $K_{aE} H$	6016 N 1352 lbf

What are the applications of the B7208-E-T-P4S-UL bearing?

- **Machine tool manufacturing (spindles, grinding heads):** Achieve extremely high speeds and machining accuracy, improving surface quality and production efficiency.
- **Aerospace (accessory gearboxes, gyroscopes):** Maintain high reliability and long lifespan during high-speed operation, adapting to harsh environments.
- **Precision instruments (measuring equipment, optical instruments):** Provide extremely low vibration and smooth operation, ensuring measurement accuracy.
- **High-speed motors (electric spindles, permanent magnet motors):** Support ultra-high speed operation, reducing temperature rise and power consumption.
- **Semiconductor equipment (wafer dicing machines, lithography machines):** Ensure micron-level positioning accuracy and long-term stability, improving yield.
- **Medical devices (CT scanners, surgical robots):** Achieve quiet and smooth rotation, meeting medical safety standards.
- **Robotics (joint reducers):** Improve joint response speed and repeatability, enhancing dynamic performance.

How should choose the right model for a High precision angular contact ball bearings?

Following the naming logic of "basic model + suffix," the key steps for selection are as follows:

Step 1: Contact Angle Determines Basic Load-Bearing Direction

Ultra-precision angular contact ball bearings have contact angles indicated by letters following their basic model number:

C = 15° Contact Angle: Suitable for ultra-high-speed rotation, relatively weak axial load-bearing capacity, a typical choice for high-precision, high-speed operation scenarios.

D (or AC) = 25° Contact Angle: General purpose, balancing high speed and axial rigidity.

E (or B) = 40° Contact Angle: Suitable for heavy-duty applications, good axial rigidity, but lower limiting speed.

Step 2: Design Variations Determine Performance Orientation

Ultra-precision spindle bearings have various internal design variations, identified by prefixes or suffixes:

No Code: Standard design, steel balls.

HC: Hybrid ceramic balls (silicon nitride balls + steel rings), enabling higher speeds, electrical insulation, lower heat generation, and longer lifespan.

X-life: Schaeffler's top-quality designation, representing higher load-bearing capacity, lower friction, and longer lifespan.

E: High-performance design, usually indicating superior performance. Internal Geometry

Step 3: Cage Code

Cage material directly affects high-speed performance and operational stability:

T: Laminated phenolic resin cage, outer ring guided (standard high-speed design)

TP: Also phenolic resin cage, but for rolling elements guided

P: Plastic cage (e.g., PEEK material)

G: Solid brass cage, suitable for higher temperatures or special operating conditions

Step 4: Universal Pairing and Preload

Ultra-precision bearings are all universally paired, allowing for arbitrary back-to-back, face-to-face, or tandem configurations. Preload is indicated by the following suffixes:

UL: Universal Light – Suitable for high-speed applications

UM: Universal Medium – Suitable for high-speed applications

UH: Universal Heavy – Suitable for high-rigidity applications

LO: Light Preload

L: Another way to indicate light preload

Step 5: Accuracy Grade

FAG ultra-precision bearing accuracy grade suffixes:

P4: ISO Class 4 accuracy, standard ultra-precision grade

P4S: Schaeffler standard, a higher accuracy grade than P4 (operating accuracy can reach P2 level), the standard configuration for FAG spindle bearings

P2: ISO Class 2 accuracy, the highest grade

Typical Model Interpretation

Using HC7008-E-T-P4S-UL For example:

HC: Hybrid ceramic ball bearing (ceramic ball + steel ring)

7008: 70 series, 40mm inner diameter

E: High-performance design (25° contact angle)

T: Phenolic resin cage, outer ring guided

P4S: Ultra-precision grade (higher than P4)

UL: Universal mating, light preload

This model designation indicates: a 70 series hybrid ceramic ball bearing with a 40mm inner diameter, 25° contact angle, phenolic resin cage, P4S precision grade, universal mating, and light preload—suitable for general applications such as high-speed machining center spindles.

Key Selection Points Summary

Determine Contact Angle: C (15° high speed), D/AC (25° general purpose), E/B (40° heavy load)

Select Material: No designation = steel balls, HC = ceramic balls (higher performance)

Match Cage: T (phenolic resin) suitable for most high-speed applications
Set Preload: UL (light preload) general purpose, UM/UH for high rigidity requirements
Confirm Accuracy: P4S is the standard configuration for FAG ultra-precision bearings

Following the order of "Contact Angle → Material → Cage → Preload → Accuracy" will provide a complete understanding of the FAG ultra-precision angular contact ball bearing models.

What is the mounting procedure for B7208-E-T-P4S-UL bearings?

Cleaning and Inspection: Clean the bearing in a dust-free environment. After a rough wash to remove contaminants, perform a fine wash until the bearing feels smooth and responsive to the touch. Simultaneously check the accuracy of the mating surfaces of the shaft and bearing housing.

Measurement and Fitting: Precisely measure the bearing's inner and outer diameters. Mark the corresponding positions on the shaft and housing bores for alignment during assembly to compensate for any deviations.

Installation and Positioning: Apply pressure evenly using a specialized tool, focusing only on the interference fit rings. If heat fitting is used, tighten the inner ring during cooling to prevent clearance from affecting the preload.

Preload Adjustment: When installing in pairs, ensure the parallelism of the inner and outer spacers is $\leq 1\mu\text{m}$. Adjust the preload force to the specified value by grinding the spacers.

Lubrication Inspection: Add the specified amount of grease or oil mist lubricant. After installation, manually rotate the bearing to check its flexibility and operating noise.

Special Note for mounting B7208-E-T-P4S-UL bearings?

Clean Environment: Operation must be performed in a dust-free cleanroom with humidity $\leq 65\%$ to prevent dust and impurities from affecting accuracy.

No Striking: Direct striking of the bearings is strictly prohibited. Special tools must be used, and force must be applied evenly.

Matching Marks: Bearings used in pairs are not interchangeable. Installation must strictly follow the factory matching marks.

Rust-Proof Storage: Long-term storage requires regular rust-proofing treatment. Maintain ventilation and avoid corrosive gases.

Tradebearing(TBS): <https://en.tradebearings.com/>

Email: admin@tradebearings.com

Whatsapp/Mob.: +86 15906428604